

## Heat On Demand Advantage® RS+ Induction Heating Activator Model ADV650+

Aladdin's Heat On Demand Advantage® RS+ induction heating activator revolutionizes kitchen operations, giving you features, performance and efficiencies that most other meal-delivery systems just can't deliver. Bases are activated in just 15 seconds and maintain food temperatures at or above 140°F (60°C) for 75+ minutes<sup>1</sup> when using a preheated plate, and 53+ minutes<sup>2</sup> without using a preheated plate.



The prominent **LED status light** displays a different vibrant color at every stage.

**HEAT ON DEMAND**

Advantage **RS+**



**75+**  
MINUTES  
HOLD TIME



**12**  
SECONDS  
CYCLE TIME

### Heat On Demand Advantage® RS+ Benefits

- Hot food for higher patient satisfaction scores.
- Time-tested design and component reliability.
- Less heating equipment for a cooler kitchen.
- Simple operation for greater employee satisfaction.
- No dish heater required!
- Exceptional temperature holding performance.

### Performance

- When using a preheated plate, and Aladdin Radiance® dome, Advantage® RS+ maintains food temperatures at or above 140°F (60°C) for 75+ minutes<sup>1</sup>, and for 53+ minutes<sup>2</sup> without using a preheated plate.
- 15-second heating cycle activates up to 4 bases per minute.
- Bases stay cool to the touch and fit standard 9" entrée plates.

### Construction

- Durable stainless steel countertop design.
- Solid-state electronic controls for enhanced reliability.
- Robust polymer centering guide for hassle-free base insertion and removal.
- Designed for use in commercial kitchens.

### Standard Features

- **LED status light** signals cycle change (white / idle; red / heating; green / ready; yellow / error).
- **Compact, low-profile design.**
- **Automatic voltage calibration** adjusts activator settings for 208 to 240 volt power.
- Cycle time not affected by voltage fluctuations.
- Error prevention logic eliminates the guesswork.
- Visual and audible indicators alert when the base is ready.
- Energy saving automatic shut-off.
- An automatic holding cycle keeps bases ready for use during breaks in the action.
- Internal fans keep electronics cool during heavy use.
- Base and activator diagnostics.
- Easy to remove washable air filter.
- Easy to clean.



### Sustainability

Efficient induction technology provides significant energy savings.

- 81% - 85% energy savings<sup>3</sup> as compared to a system requiring a convection heated base and plate, depending on the number of meals served per serving period.
- 63% energy savings<sup>3</sup> as compared to a system requiring a convection heated plate and an induction heated base.

# Heat On Demand Advantage® RS+

## Induction Heating Activator

### Model ADV650+

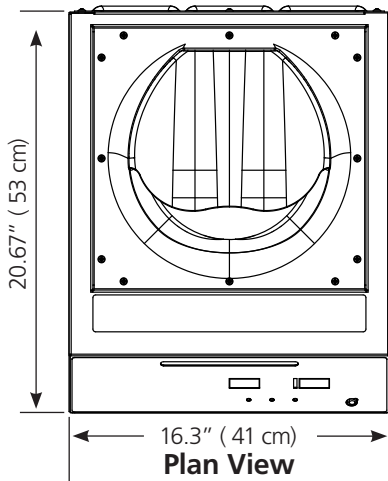

### Advantage RS+ System

Activates Advantage (IHB26) bases which accommodate standard 9" (22.9 cm) dishware.

Visit [aladdintemprite.com](http://aladdintemprite.com) to see all Advantage base color options.

Heat On Demand Advantage® bases stay cool on the sides, so they're safe to handle without gloves or a base lifter, and they're safer for patients and residents, too. They accommodate standard 9" (22.86 cm) dishware and domes.

*Use only with Aladdin Heat On Demand Advantage® bases.*

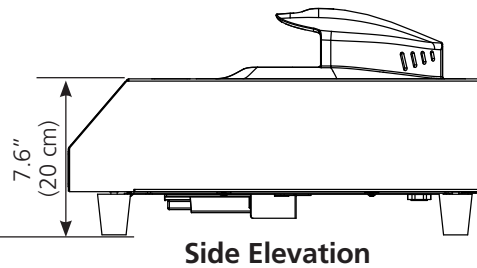
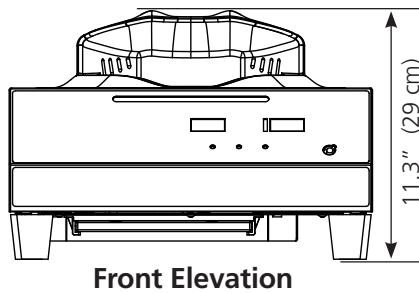

L15-20P NEMA  
Twist-Lock Plug

### Heat on Demand Advantage® RS+ Technical Specifications

Model Number	Electrical <sup>4</sup>	Cord Set/ Plug	Width	Depth	Height	Weight	Shipping Weight
 ADV650+	Volts: 208-240 Hertz: 50/60 Phase: Three Max amp draw: 15 Min. amp capacity: 20	L15-20P (4-wire) 5.5' (167.6 cm) cord with twist-lock plug	16.3" (41 cm)	20.6" (53 cm)	11.3" (29 cm)	34 lbs. (15 kg)	49 lbs. (22 kg)

<sup>1</sup> 11-oz. (311 grams) of food input at 165°F (74°C) with a 165°F (74°C) preheated plate, Aladdin Radiance™ dome (65+ minutes hold time with other Aladdin domes).

<sup>2</sup> 11-oz. (311 grams) of food input at 165°F (74°C) without a preheated plate, Aladdin Radiance™ dome.

<sup>3</sup> Energy savings calculations will vary based on exact equipment mix and local energy rates. Percentage savings based on using an ambient plate.

<sup>4</sup> Auto-shift voltage feature automatically calibrates activator settings for 208-240 volt power. Unit should be operated on a 20-amp dedicated circuit.

Complies with CISPR 14/EN55014/EN6100.



#### FOR SERVICE AND WARRANTY INFORMATION

**ADV650+:**  
1 YEAR, Parts and Labor  
**Centering Guide:**  
2 YEARS, Parts



Intertek Intertek

Visit [aladdintemprite.com/patents](http://aladdintemprite.com/patents) for patent information.

250 E. Main St. | Hendersonville, TN 37075 | Customer Service: 800.888.8018 | Tech Service: 800.888.5426 | Fax: 888.812.9956 | [aladdintemprite.com](http://aladdintemprite.com)

©2021 Aladdin Temp-Rite.® All rights reserved. Note: Specifications are subject to change without notice.

S211020ADVRS+ Rev-2

